

AARON MANUFACTURING INC.

DATE: 9-17-04

WORK TABLES AND CABINETS WITH SLIDING DOORS MODEL # AWT-CS SERIES

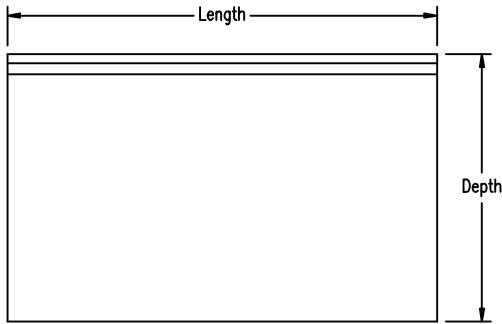

PLAN VIEW

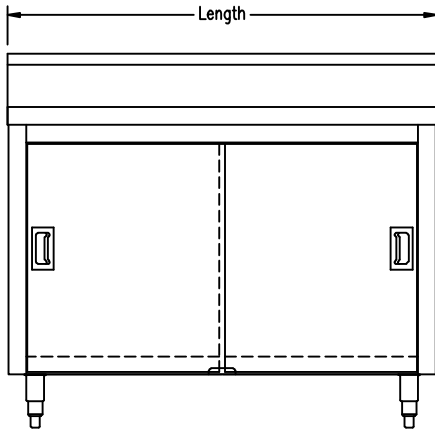

FRONT ELEVATION VIEW

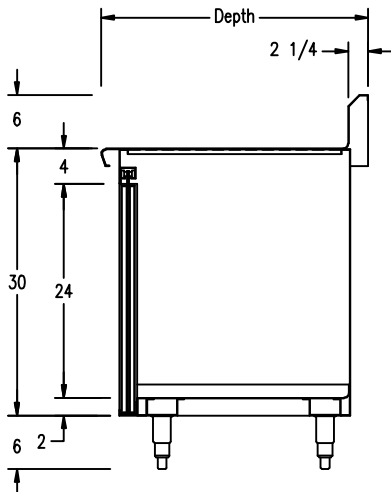

SECTION

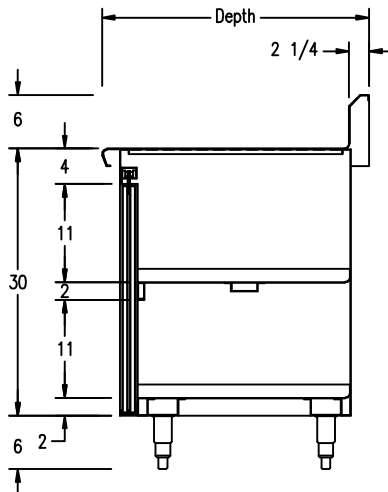

SECTION

OPTIONAL INTERMEDIATE SHELVING

MODEL # AWT-CS SERIES SPECIFICATIONS							
depth x length	# of	weight	# of	model #			
				depth	length		
in.	legs	lbs.	doors	mm	mm	in.	mm
24" x 36"	4	150	1	610	914	24	36
24" x 42"	4	200	2	610	1067	24	42
24" x 48"	4	220	2	610	1219	24	48
24" x 60"	4	245	2	610	1524	24	60
24" x 72"	4	305	3	610	1829	24	72
24" x 84"	6	320	3	610	2134	24	84
24" x 96"	6	370	4	610	2438	24	96
24" x 108"	6	395	4	610	2743	24	108
24" x 120"	6	420	4	610	3048	24	120
30" x 36"	4	175	1	762	914	30	36
30" x 48"	4	250	2	762	1219	30	48
30" x 60"	4	280	2	762	1524	30	60
30" x 72"	4	340	3	762	1829	30	72
30" x 84"	6	370	3	762	2134	30	84
30" x 96"	6	425	4	762	2438	30	96
30" x 108"	6	455	4	762	2743	30	108
30" x 120"	6	485	4	762	3048	30	120
36" x 36"	4	185	1	914	914	36	36
36" x 48"	4	260	2	914	1219	36	48
36" x 60"	4	290	2	914	1524	36	60
36" x 72"	4	350	3	914	1829	36	72
36" x 84"	6	385	3	914	2134	36	84
36" x 96"	6	440	4	914	2438	36	96
36" x 108"	6	470	4	914	2743	36	108
36" x 120"	6	500	4	914	3048	36	120